

Course: B. Tech.

Sem: I/II

Subject Name: Engineering Mechanics

Subject Code: EM1203

Max Marks: 60

Date: 13-05-2019

Duration: 3 Hrs

Instructions to the Students:

1. All questions are compulsory.
2. Use of non-programmable scientific calculators is allowed.
3. Assume suitable data wherever necessary and mention it clearly.

Marks

Q. 1 Solve any three from the following.

- A) Define the following: Principle of Transmissibility of Forces, Equilibrant, and Dynamics. (4)
- B) Compute the resultant in magnitude and direction of a parallel force system shown in figure. (4)

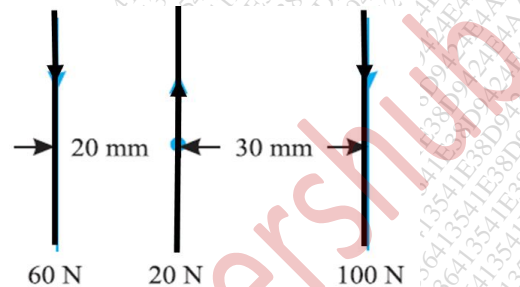

- C) A uniform beam AB of weight 100 N and 6 m long had two bodies of weights 60 N and 80 N suspended from its two ends as shown in Fig. Find analytically at what point the beam should be supported, so that it may rest horizontally. (4)

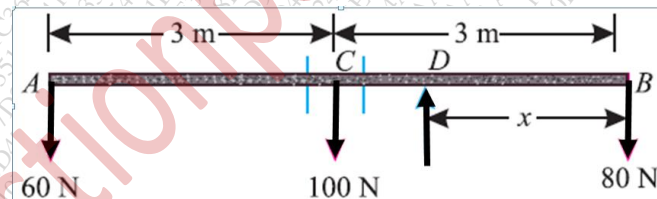

- D) Define a couple and write the characteristics of a couple. (4)

Q.2 Solve any two from the following.

- A) Explain in brief with neat sketch the different types of loads studied in engineering mechanics. (6)
- B) Determine the support reactions and forces in all the members of the truss subjected an external force F as shown in figure. (6)

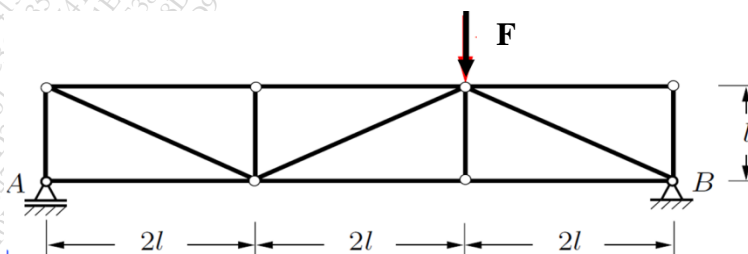

- C) Determine the centroid of the area shown in figure. (All dimensions are in mm) (6)

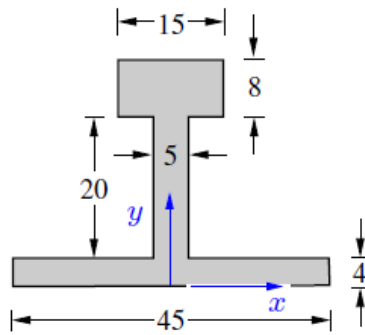

Q. 3 Solve the following.

- A) Obtain an expression for maximum height of a projectile projected from a horizontal plane. (6)
- B) A stone is thrown vertically upwards, from the ground, with a velocity 49 m/s. After 2 seconds, another stone is thrown vertically upwards from the same place. If both the stone strike the ground at the same time, find the velocity, with which the second stone was thrown upwards. (6)

Q.4 Solve the following.

- A) State and explain in brief D'Alembert's principle. (6)
- B) A flywheel of mass 8 tonnes starts from rest, and gets up a speed of 180 r.p.m. in 3 minutes. Find the average torque exerted on it, if the radius of gyration of the flywheel is 60 cm. (6)

Q. 5 Solve the following.

- A) State and prove the law of conservation of energy. (8)
- B) Calculate the work done in pulling up a block of mass 200 kg for 10 m on a smooth plane inclined at an angle of 15° with the horizontal. (4)

OR

- B) A spring is stretched by 50 mm by the application of a force. Find the work done, if the force required to stretch 1 mm of the spring is 10 N. (4)

*** End ***